



SureStep™ Mono Installation Guide

Thank you for your interest in Hawk Research Laboratories' SureStep Mono bathtub step system. This installation manual includes an overview of the SureStep Mono installation kit and step-by-step instructions for SureStep Mono installation.

SureStep Mono Installation Kit

The SureStep Mono installation kit includes the following items:

- One SureStep Mono
- One SureStep Mono Support Box Structure (large & small box)
- Template to be used for cutting the tub
- Two tubes of required adhesive and angled extension

Tools & Materials

In addition to the items included in the installation kit, the following tools and materials are recommended to have on hand for installation.

Butane Torch	Hammer
Card Paper	Jigsaw with 2" Blade
Caulking Gun (High Torque Ratio)	Masking Tape
Chisels	Mirror (small)
Deburring Tool (i.e., file, knife)	Pliers
Drain Screens	Pressure Treated 2 X 4's
Drill & Drill Bits	Protective Eye Wear
Drop Cloths	Reciprocating Saw with Metal Blades
Drywall plane or Rasp	Scissors
Drywall Router	Screw Driver
Dust Masks	Screws- Assorted Sizes
Dust Pan & Brush	Side Grinder with 4.5" Diamond Blade
Ear Protection	Red Sharpie Marker
Extension Cord	Utility Knife
Fire Extinguisher	Vacuum with Attachment
Gloves	Wood Shims

Several of these items are available from Hawk Labs. Please refer to our product catalog at www.hawklabs.com



Preparing the Tub

1. Before beginning any work, it is important to inspect the tub for existing chips, markings or other types of damage. It is always wise to inform the owner or manager of any existing damage prior to beginning the installation process.
2. Prior to beginning the installation, remove any personal items from the bathroom area to create extra space during the installation and to prevent possible damage or exposure to dust and debris that may result during the installation process.
3. One approach to minimize the areas where dust can settle is to use a 2-ply drop cloth with the paper side up to catch and trap dust and other shavings. In particular, a drop cloth should be taped into the bottom of the tub. This will help to collect debris as well as to help prevent accidentally scratching the bottom surface of the tub. The tub drain should be completely covered to prevent any shaving from going into the drain. Make sure that there is no water or dampness in or around the tub.

Due to the significant amount of dust created when cutting a cast-iron tub, it is recommended that all walls and surfaces are covered, including the floor, before cutting the tub. See other considerations for cutting cast-iron tubs in the following section.

4. Once the tub area is prepared for installation, it is necessary to mark the tub to determine the section that will be cut to make room for the SureStep Mono. First, measure the length of the tub and determine the midpoint of the tub and measure back, half the distance of the SureStep Mono itself. Using the template that was included in the installation kit, place the template flush against the tub and begin tracing. Use a red sharpie marker so as to make the lines that are traced easily visible. Flip the template over and now trace the outside of the tub. Keep in mind that it may not be possible to place the SureStep Mono directly in the center of the tub due to obstructions in the tub area such as the placement of sinks, vanities or commodes and the use of shower seats may also warrant moving the opening.



Cutting the Tub

The tub has been marked and is ready to cut. Safety is of highest importance and it is critical to remember to use the proper safety equipment when cutting the tub. Protective eye and ear wear and filter mask are strongly recommended.

The SureStep Mono can be installed in fiberglass, steel or cast-iron tubs. On fiberglass or steel tubs, use a side grinder with the diamond blade to make necessary entry points for the reciprocating saw. For cast-iron tubs, the side grinder with the diamond blade is the only cutting tool used. **If you are cutting a cast-iron tub, please read the special considerations noted below before beginning to cut.**

1. The first corner notches will be made with the side-grinder as illustrated in Figure 1 below.
2. Using the reciprocating saw on fiberglass and steel tubs, cut out the bottom markings on each side of the tub.

FIGURE 1

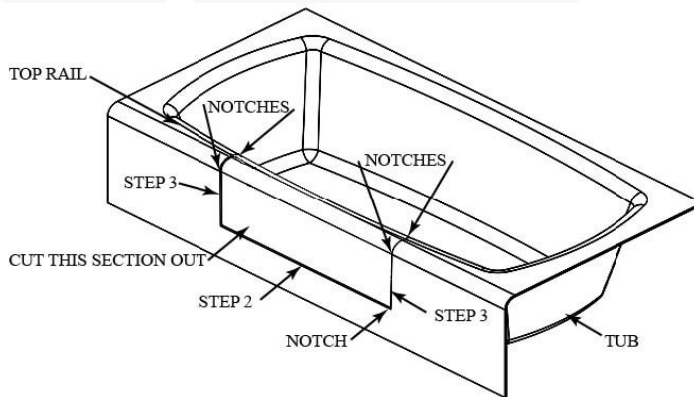

3. Then cut all four downward cuts. Finish by cutting the two adjoining top pieces.
4. The opening for the SureStep Mono is now completed and you can remove the cut-out section. Use caution when removing the cut-out section as there may be sharp or jagged edges both on the cut-out segment and along the edges of where the cuts were made on the sides of the tub. It is helpful to spend a moment to file down any potential hazard areas. This prevents potential snags with fitting the SureStep Mono and reduces the risk of injury.
5. After the cut out section of the tub has been removed, take a few moments to clean the area in around the tub. Using a dust pan and broom, sweep all dust and shavings. Complete the clean-up by thoroughly vacuuming the entire area. Wash your hands before you start any work on the step itself. This will eliminate transferring any dirt or dust to the step.



SPECIAL CONSIDERATIONS FOR CUTTING CAST-IRON TUBS

Due to the significant amount of dust created when cutting a cast-iron tub, it is recommended that you cover all tub and exposed bathroom walls and surfaces (including the floor) with a 2-ply drop cloth to minimize the amount of dust that can settle. Also, it is recommended that the installer wears protective coveralls and shoe covers, in addition to the protective wear outlined earlier, to minimize the clean-up after cutting out a cast-iron tub.

Please note that there are several differences when cutting out a cast-iron tub compared to a fiberglass or steel tub. The side-grinder with a 4.5" diamond blade is the only tool used when cutting a cast-iron tub. Cast-iron tubs are a bit more challenging to cut. Vacuum the dust and shavings as you cut the tub to minimize dust output when cutting the cast-iron. Follow the same pattern when cutting a cast-iron tub as described for the fiberglass and steel tubs. Begin by cutting the bottom lines of your template, followed by the downward vertical cuts leaving the top adjoining pieces for last.

Be cognizant of potential safety issues when cutting the tub such as sparks generated during cutting as well as items that may be located within the tub wall such as water lines, electrical lines, insulation or other items.

Measuring & Cutting the SureStep Standard

Once you have completed cutting out a section of the tub, you can begin to fit the SureStep Mono into the tub opening. The first step is to determine which size SureStep Mono you will need to complete the installation. The SureStep Mono is offered in three (3) sizes to fit tubs of varying widths. First, measure the top rail width measurement as well as the width measurement approximately 9.75" down the tub (bottom measurement). Based on these measurements, please consider the following:

- **Small/Narrow SureStep Mono**
 - The maximum top rail measurement to order a small/narrow SureStep Mono is 4.0".
 - The maximum bottom measurement to order a small/narrow SureStep Mono is 4.75".
- **Medium SureStep Mono**
 - The maximum top rail measurement to order a medium SureStep Mono is 4.5".
 - The maximum bottom measurement to order a medium SureStep Mono is 5.75".
- **Large/Wide SureStep Mono**
 - The maximum top rail measurement to order a large/wide SureStep Mono is 6.0".
 - The maximum bottom measurement to order a large/wide SureStep Mono is 7.25".

1. Take a stack of heavy card stock paper. This is the paper used to trace the cut- out section of the tub onto the SureStep Mono. Place the card paper onto the left end and trace the outline of the pattern onto the paper. Once completed, mark this tracing as "Left" to remember which side was traced. It is also helpful to place an arrow on the template to indicate which direction is the inside of the tub.



2. Repeat the process for the right side of the tub. Mark this tracing “Right”.
3. Cut out the proper templates with scissors making sure to keep to the inside of the tracings.
4. It is time to transfer the shape of our cut tub onto the SureStep Mono. Before continuing, it is recommended that a drop cloth approximately 3’ x 4’ size be placed on the floor to prevent any dust or other debris from transferring onto the SureStep Mono.
5. Place the right end of the SureStep Mono on the ground in order to trace the left side of the SureStep Mono. Place the top of the paper template approximately ½” from the top of the SureStep Mono (Figure 3). Place the tracing on the step so the slope is similar to that of the tub. Trace the outline of the paper onto the SureStep Mono with a continuous line. Continue the lines with a straight edge down and around the corners. Repeat the same procedure for the right end of the SureStep Mono. Remember to place the paper template approximately ½” down from the top of the SureStep Mono before beginning to trace. Continue the lines with a straight edge down and around the corners.

*FIGURE 3 – SIDE VIEW OF
LEFT END OF STEP*

*PATTERN MARKS - - - -
INDICATE THE AREA TO BE
CUT OUT ON THE LEFT END
OF THE STEP*

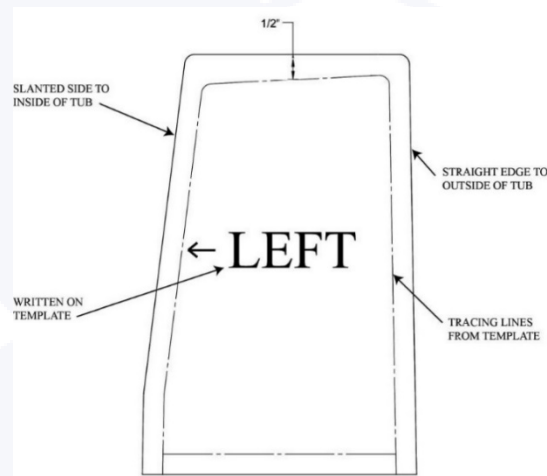

6. Place step as shown and connect each side of the outside tub line using a yard stick (Figure 4).

FIGURE 4

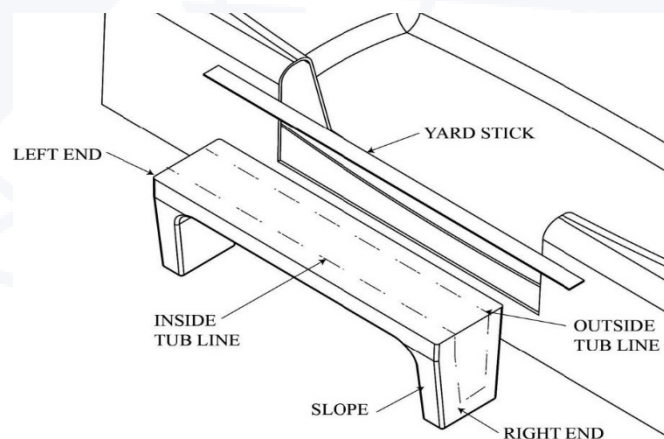



7. Use a tape measure and transfer the shape of the inside of the tub edge to the step. The inside of the tub may be irregular in shape, so measurements for the inside line must be made every 3" from one end of the SureStep Mono to the other. Once completed, use your yard stick and marker to connect the markings for the inside line.
****Alternate Method:** You may use card stock paper such as done with the sides to create a bottom template
8. Cut the SureStep Mono to fit the cut-out tub opening using a jigsaw (Figure 5). Fasten Velcro-stripping on both sides of the jigsaw to prevent making any unwanted marks on the SureStep Mono. It is important that a 2" blade is used to cut out the SureStep Mono to prevent accidentally cutting through the top of the SureStep Mono. Snap off any excess length on the stock jigsaw blade beyond 2".

USE THE JIGSAW TO CUT THE LINES TRACED ON THE STEP.

FIGURE 5

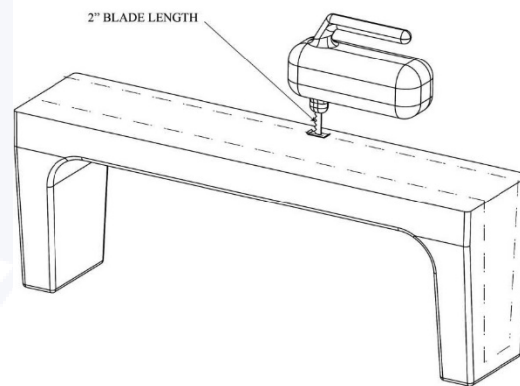

It is important that proper eye protection be worn while using the jigsaw. Cut directly on the center of the traced lines. Upon reaching the corners while cutting, tilt the jigsaw outward to prevent cutting past your lines on the vertical ends of the SureStep Mono. Remember to tilt your blade on each corner, cutting all areas that have been marked.

9. Place the SureStep Mono into position. Remember, the straight face of the SureStep Mono is on the outside of the tub. Use a small pocket mirror and look for areas on the SureStep Mono that may be catching and prohibiting the SureStep Mono from freefalling onto the tub. Use the jigsaw or drywall plane to trim the SureStep Mono where necessary.
10. Continue this process and repeat as necessary until a desirable close fit is achieved. The SureStep Mono should free fall onto the tub without catching or binding. Once final adjustments have been made, use a drywall plane or deburring tool (a common potato peeler works well) to clean up the remaining edges.
11. Having completed use of the jigsaw, take a moment to tidy the tub and work area.



Support Structure Installation

Once the SureStep Mono has been cut and a satisfactory fit into the tub opening has been achieved, it will be necessary to assemble the support box structure to provide support to the SureStep Mono. An example of the SureStep Mono and the support structure is illustrated in Figure 6.

The SureStep Mono Support Box structure consists of one small and one large Support Box. The large support box will compress over the top of the small box to the necessary height to provide support to the SureStep Mono.

FIGURE 6
SURESTEP MONO ASSEMBLY

SUPPORT BOX STRUCTURE:
LARGE SUPPORT BOX COMPRESSED
ON SMALL BOX

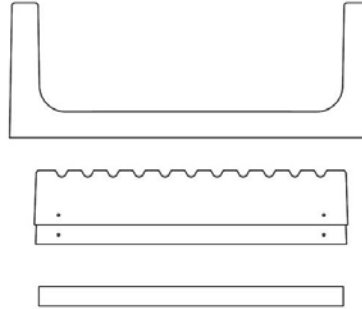

BASE 2X4 AFFIXED TO FLOOR, IF NECESSARY

It is important to understand that each tub has variations and modifications maybe necessary in the field.

1. It may be necessary to adjust the Support Box structure according to the conditions present during your installation. For example, for wooden sub-floors, begin by screwing or gluing a treated 2x4 directly to the sub-floor to serve as the base for our support structure. For concrete floors, a treated 2x4 is adhered directly to the concrete floor with adhesive. The 2x4 might need to be cut into several sections if there is a support brace in the cut out channel.
2. Build the Support Box structure to appropriate height. If working with a concrete sub-floor, thoroughly inspect and clean the floor in the tub cut out channel prior to securing the treated 2x4. Remove any materials from the concrete that may cause an uneven surface. Apply adhesive directly to the concrete floor. Insert the 2x4's and thoroughly spread the adhesive on the concrete.
3. If wood sub-floor is present, screw the 2x4 directly to the sub-floor.
4. Prior to inserting the small Support Box, it is first necessary to secure a 22 ½" long 2x4 into the channel of the small Support Box. Place a bead of adhesive around the inside of the Support Box and insert the 2x4. Place several screws into the small Support Box to properly adhere the 2x4 into proper position.



FIGURE 7
SMALL SUPPORT BOX

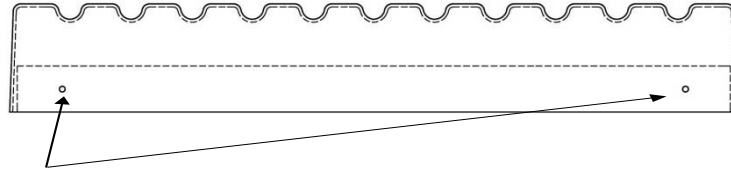

Dry Wall Screws Holding 2x4s (each side)

5. Insert the small box in the channel. At this point, do not adhere the small support box to anything. Place the large support box into the channel and over the top of the small box. Place the SureStep Mono into position and compress the SureStep Mono downward to determine the proper height and placement for the support box structure.
6. Once the support of the SureStep Mono has been achieved, remove the step and mark both the left and right ends of the small box where the large box is compressed while the boxes are in the tub opening channel. Once properly marked, remove both support boxes and label the markings "Left" and "Right" to avoid potential confusion. Uncompress the two support boxes from one another and begin the process to permanently adhere the boxes in proper position.
7. Apply adhesive around the inside perimeter of the large box. Compress the small and large support box structures back together to the appropriate markings made earlier on the small box. Place the support structure back into the channel and insert the SureStep Mono to verify that proper placement has been achieved. Secure both sides of the support structure by placing two screws in each side (Figure 8).

FIGURE 8

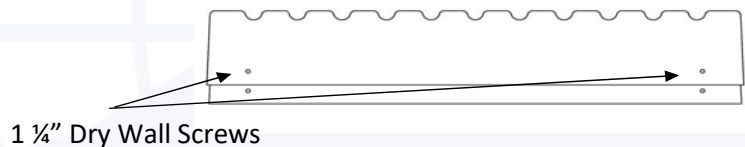

8. Apply adhesive to the tops of the 2x4's that are already in place in the channel, if they are needed for height adjustment, and insert the support box structure.
9. Place the SureStep Mono into position once more to inspect the fit and position. This is the final opportunity to make any adjustments if necessary.
10. Apply adhesive to the top of the large support box. It is recommended that an extra bead of adhesive be placed on the ends of the large support box as the step curves up toward the ends. Place a substantial bead of adhesive on the top left and right side of the tub where the SureStep Mono will be seated. Adhesive on the top of the tub reinforces the SureStep Mono.



11. Prior to placing the SureStep Mono into the channel, it is necessary to gently pass a low flame several times along the perimeter of the cut out where the tub is met. This will help promote bonding between the step and the bathtub once adhesive is applied. Use caution when using the torch and do not hold heat on any area of the product, as it may discolor or melt.
12. Place the SureStep Mono into the channel and gently press into place.

Completing the Installation

1. Before finalizing the installation, first make sure the SureStep Mono is in proper position and fully compressed. Press firmly and evenly on the SureStep Mono to ensure proper placement. Thoroughly wipe the tub area with isopropyl alcohol where the adhesive will bond, and allow enough time to flash off before applying the adhesive. **DO NOT** apply the isopropyl alcohol directly on the adhesive as it will prevent the adhesive from drying or curing. **DO NOT** use to clean or smooth your final bead.
2. It is necessary to caulk around the entire perimeter of the SureStep Mono. Begin by using the recommended adhesive along the sides of the SureStep Mono. Begin on the left side and complete the process, before moving to the right side and bottom. It is recommended that you wear gloves during this step to avoid direct exposure to the adhesive.
3. Run your gloved finger along the beads and wipe the excess on a folded paper towel. Try to smooth the beads one-time only.
4. Underneath the bottom edges of the SureStep Mono are a bit more difficult to see and the angled tip should be used in completing this step. Use the small mirror to inspect the bead and to verify that all surfaces have been properly sealed.
5. It is also recommended to remove the stopper from the tub upon completion of the installation to prevent from accidentally filling the tub with water and, if desired, replace trip lever with a blank cap.
6. Spend a few minutes at the end of the job to once again clean up the tub and the bathroom area. Upon completion, place a sign on the SureStep Mono warning not to use the tub for 2 days while the adhesive cures.



HAWK RESEARCH LABORATORIES, LLC.
High Performance Coating Systems

IMPORTANT REMINDER – if completing the install on behalf of another, please leave the customer packet that includes warranty registration information with the end-user at the conclusion of the installation.

The SureStep Mono installation is now complete. Hawk Research Laboratories sincerely thanks you for your interest in the SureStep Mono and looks forward to assisting you in any way possible. Visit our website at www.hawklabs.com or call us toll-free at 1 800 321 4295 with any questions or concerns you may have.

